

HandBOOK

What's IN It?

TRAVEL BAG

ESSENTIALS FOR A WEEKLONG BIKE VACATION

So, you and your bike are about to head off for a week of quality time. (See *Cycling* 101, p. 115, for tips on transporting your rig.) Good for you...as long as your gear bag includes all the basics. While there's no accounting for the homey comforts you might choose to schlepp along, with this bag of bike-travel basics, you'll have everything you need to see you through once you arrive at your dream destination.—*Brian Fiske*

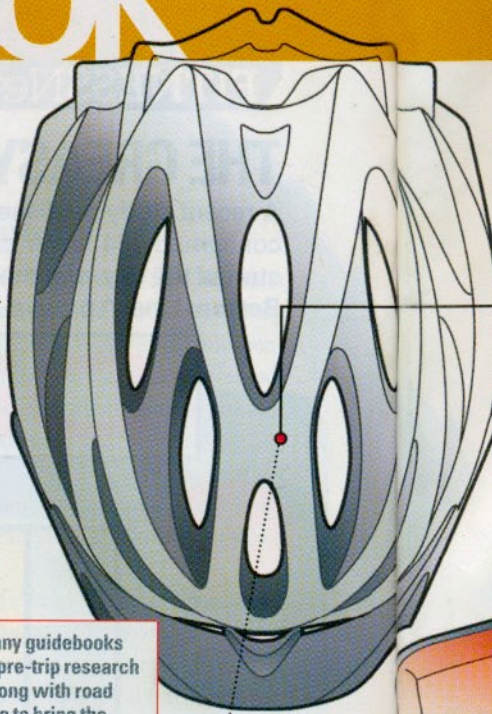

RIDING GEAR Be minimalist. Bring your helmet, of course; if it's in your checked baggage, surround it with soft goods for extra protection. Also pack your gloves, shoes, socks (three pairs), shorts (two pairs), jerseys (two), knee warmers, arm warmers, vest, rain jacket and rain pants. After the ride, wash out the day's riding clothes in the sink and hang them to dry; the next day, ride in your second set of clothes. Adjust the necessities accordingly: In colder weather, bring tights, a long-sleeve jersey, maybe even shoe covers and ear warmers.

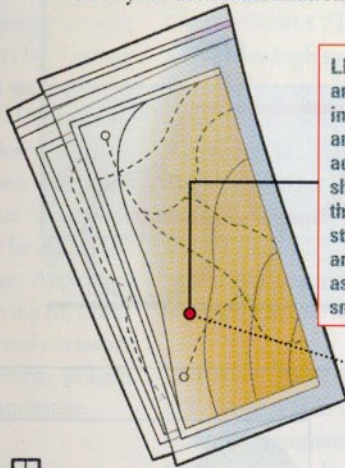

LITERATURE Slip any guidebooks and printouts of your pre-trip research into a Zip-Loc bag. Along with road and trail maps, be sure to bring the address and phone number of a bike shop or two, as well as directions to the shops from where you'll be staying. Visit the shops when you arrive and load up on local knowledge, as well as energy bars, drinks and any small parts you didn't bring with you.

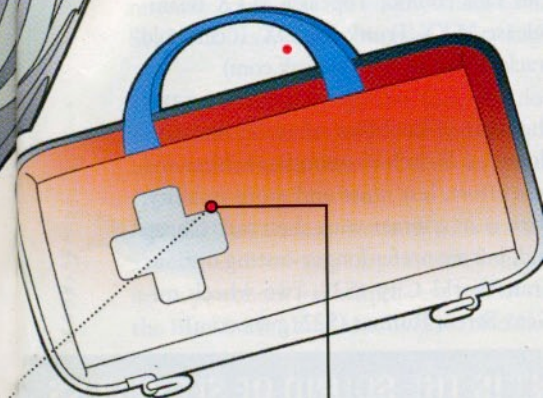

BODY REPAIR KIT Your cycling first-aid kit should contain, at minimum: sunscreen, ibuprofen, assorted adhesive bandages, antibiotic ointment, anti-diarrhea medicine, gauze pads and tape, and any prescription medications. Other good additions: insect repellent, **Ivy Block**, hydrocortisone cream and the phone number and address of the hospital closest to your destination.

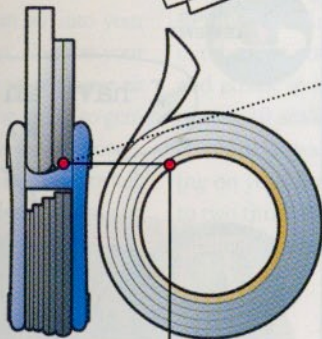

COMPACT TOOL KIT Pack a mini-pump, two tubes, patch kit, mini-tool, duct tape, zip-ties and two tire levers. If your mini-tool doesn't include spoke wrenches, a chain tool or a hex wrench large enough to fit your crank bolts, bring those along, too. Pack it all into a seat bag or hydration pack to make the most of your space. Thus armed, you're ready to fix most minor on-ride mechanicals. Got a major issue? Dig out the address to that bike shop.

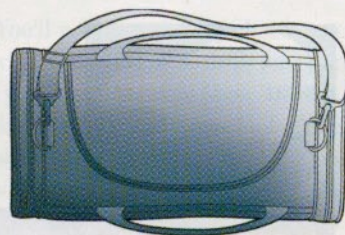

RESTING GEAR Your off-the-bike duds should be comfortable and loose-fitting, but not so shabby you get booted from the local brewpub. Again, be minimalist: For most weather conditions, you should be able to get through the week with a couple pair of shorts and pants, a few Ts (long- and short-sleeved), a pair of light-duty kicks or sandals, a fleece jacket, socks and underwear. Use common sense: You know where you're headed; you know what you'll need.

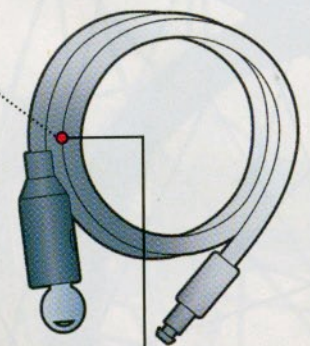

EVERYTHING ELSE Don't forget the obvious: toothbrush, toothpaste and other requisite toiletries, such as contact lens cleaner, etc. (store leak-prone containers in separate Zip-Loc bags); ID, cash, credit cards; cell phone and charger; water bottles (even if you bring a hydration pack); bike lock (for in-town jaunts); floor pump (if it fits, for faster pre-ride inflation); garbage bags (for separating crummy gear for the return trip); and the latest copy of *BICYCLING* for some in-room reading.